

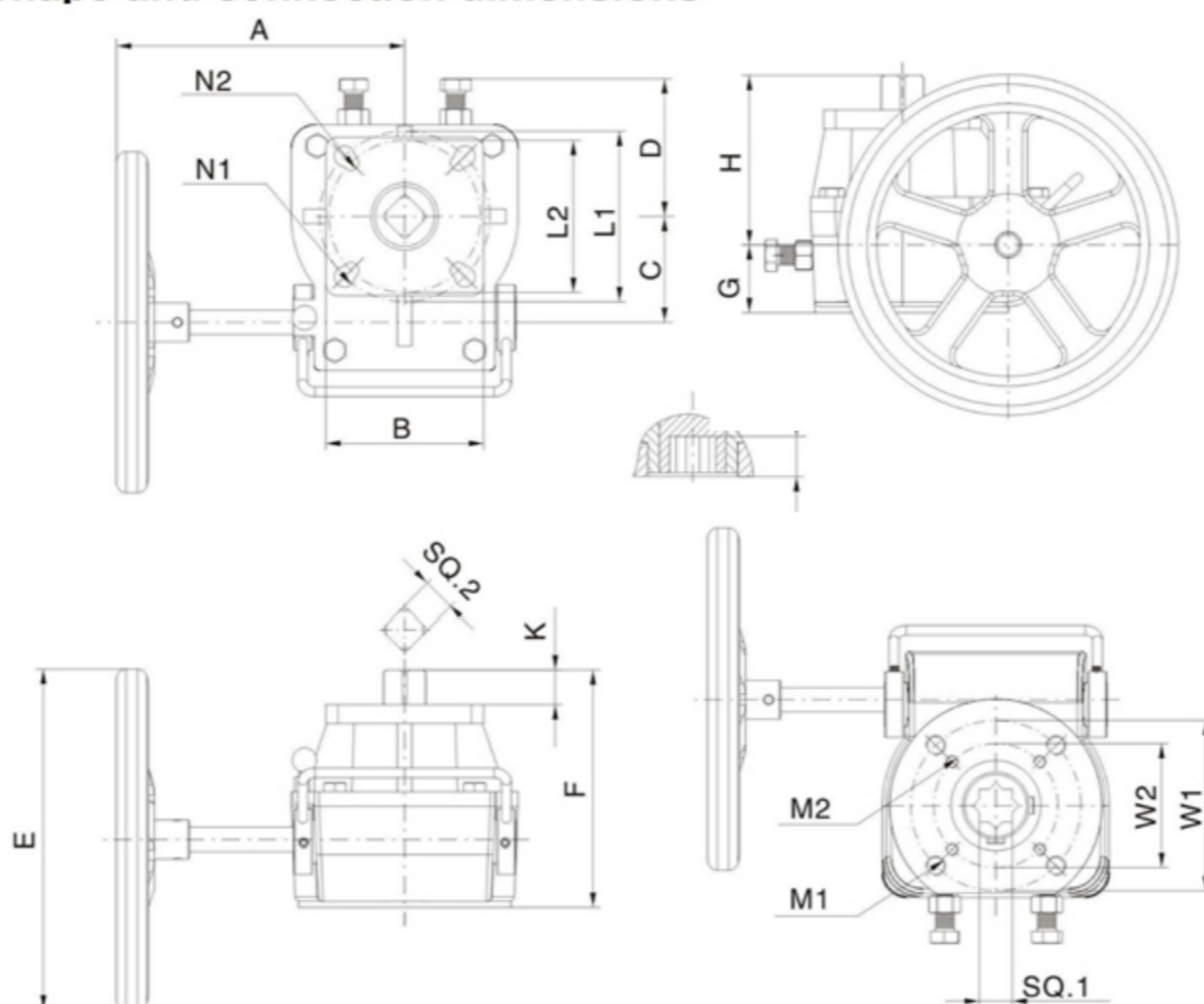

## Shape and connection dimensions



model	DG-1	DG-2	DG-3	DG-4	DG-5	DG-6	DG-7	DG-8
A	150	170	200	260	310	395	435	440
B	70	95	115	140	155	160	235	300
C	50	55	82	85	125	140	170	210
D	43	65	90	102	110	140	160	170
E	Ø180	Ø200	Ø280	Ø300	Ø400	Ø500	Ø600	Ø600
F	120	127	150	195	209	233	243	252
G	35	40	40	60	55	60	60	65
H	85	87	110	135	154	172	183	187
J	16	19	24	29	40	50	58	58
K	15	19	22	28	39	48	55	55
M1	M8x4	M10x4	M12x4	M16x4	M20x4	M20x4	M16x8	M16x8
M2	M6x4	M8x4	M10x4	----	----	---	----	---
W1	70	102	102	140	165	165	200	254
W2	50	70	70	----	----	---	----	---
SQ.1	14	17	22	27	36	46	55	55
N1	Ø10x4	Ø12x4	Ø14x4	Ø18x4	Ø22x4	Ø22x4	Ø18x8	Ø18x8
N2	Ø8x4	Ø10x4	Ø12x4	Ø16x4	Ø18x4	---	----	---
L1	70	102	125	140	165	165	200	254
L2	50	70	102	125	140	---	----	---
SQ.2	14	17	22	27	36	45	55	55

## DECLUTCH GEARBOX

모델	비율	핸들직경	중량(Kg)	적용 모델
DG-01	26:1	Ø180	2.6	AT50-75
DG-02	30:1	Ø200	4.0	AT88-100
DG-03	38:1	Ø280	6.5	AT115-145
DG-04	54:1	Ø300	13	AT160-190
DG-05	80:1	Ø400	32	AT210-240
DG-06	78:1	Ø500	43	AT270-300
DG-07	98:1	Ø600	65	AT350

## \* 제품 규격

모델	비율	입력토크	출력토크	핸들직경	중량(Kg)
DG-1	26:1	50	100	Ø180	2.6
DG-2	30:1	60	215	Ø200	4.0
DG-3	38:1	90	434	Ø280	6.5
DG-4	54:1	110	1000	Ø300	13
DG-5	80:1	140	2000	Ø400	32
DG-6	78:1	200	3500	Ø500	43
DG-7	98:1	200	4200	Ø600	65
DG-8	100:1	200	6000	Ø600	95