

06

www.goldenrules.co.kr

Golden Rules Co.,Ltd

Liquid, Oil
Inline type Vortex Flow Meter

KC-7760 Series 볼텍스유량계 VORTEX FLOWMETER



The nation's development item, 100% domestic goods, Patent **NO.** 10-1660226

6. VORTEX FLOWMETER

6-1. 인라인형 와류유량계 KC-7760 Series

Vortex Flowmeter

제품 사양



일반형 (Compact Type)
KC-7761-J



온도-압력 보정형
(Temp'-Pressure Compensation Type)
KC-7764-J

- 정확도 : $\pm 1.0 \%$
- 압손실 : Resistance Coefficient (Cd) ≤ 2.4
- 측정 가능 유체 온도 : $(-40 \sim 350) ^\circ\text{C}$
- Power : $(12 \sim 24) \text{ V DC}$
- 방폭등급 : ExiaIICT6
- Connection Pressure : 1.6 Mpa, 2.5 Mpa, 4.0 Mpa etc.
- 신호 출력 :
Voltage Pulse Low Level $\leq 1 \text{ V}$
High Voltage $\geq 6 \text{ V}$
(4 ~ 20) mA 전류출력
- 통신출력 : RS-485 (Std.)

설치

KC-7760 시리즈 와류유량계는 수평, 수직(하단부에서 상단부로 흐르는 수직방향) 배관에 설치 가능하며 아래와 같이 전/후단에 직관부를 두어야 합니다.

same core contraction and fully open valve		Two 90° elbows in the same plane	
same core pipe expanding		Two 90° elbows in the different plane	
One 90° elbow		Adjustable valve and half-open valve	

The information contained herein is subject to change without notice.

도면치수 KC-7760

[단위 : mm]

플랜지 타입	
구경 Nominal Diameter	C to C (L)
25	170
32	170
40	190
50	190
65	220
80	220
100	240
125	260
150	280
200	300
250	360
300	400

웨이퍼 타입		
구경 Nominal Diameter	L1	L2
25	65	95
32	65	95
40	75	109
50	75	109
65	75	117
80	75	109
100	90	132
125	100	146
150	120	170
200	150	200
250	160	214
300	170	224

삽입형
 Total Length : 740 mm
 Mounting : $\Phi 90 \times 90 \text{ L}$

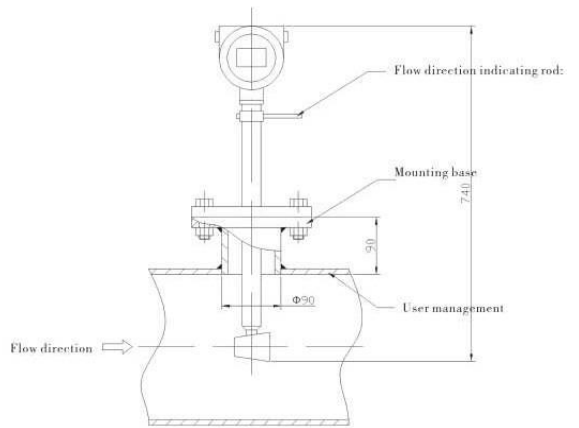
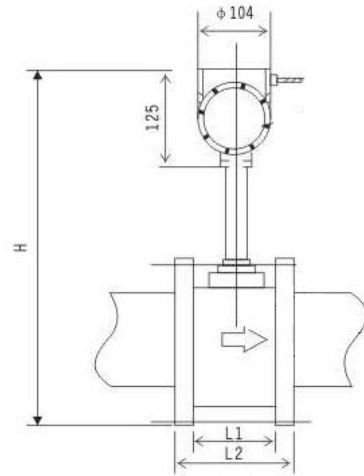
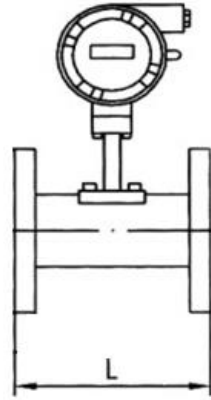

※ 센서의 형상은 제조사 사정에 따라 변경될 수 있습니다.

유량 범위표 (Flow Range)

1. 액체와 가스 유량 범위표 (Liquid and the flow range of working condition gas)

구경 Size (mm)	물 Water	가스 Normal Pressure and Temperature Air (NPT Air)
	Standard Measuring Range (m³/h)	Standard Measuring Range (m³/h)
25	1.3 ~ 13	8 ~ 60
32	1.5 ~ 15	14 ~ 100
40	3 ~ 30	18 ~ 180
50	4 ~ 40	30 ~ 300
65	6 ~ 60	50 ~ 500
80	13 ~ 130	70 ~ 700
100	20 ~ 200	100 ~ 1000
125	36 ~ 360	150 ~ 1500
150	50 ~ 500	200 ~ 2000
200	100 ~ 1000	400 ~ 4000
250	150 ~ 1500	600 ~ 6000
300	200 ~ 2000	1000 ~ 10000

2. 포화증기 유량 범위표 (The quality flow range of saturated steam)

단위 [kg/h]

구경 Size (mm)		0.2	0.3	0.4	0.5	0.6	0.7	0.8	0.9	1.0	1.2	1.5	2.0
Temperature(°C)		120.23	133.54	143.62	151.84	158.94	164.96	170.41	175.36	179.88	187.96	198.40	212.37
Density(kg/m³)		1.129	1.651	2.163	2.66	3.170	3.667	4.162	4.655	5.147	6.127	7.602	10.005
DN 25	Standard Low Limit	14	17	19	22	23	25	27	28	30	33	36	42
	Standard High Limit	140	170	190	220	230	250	270	280	300	330	360	420
DN 32	Standard Low Limit	26	30	34	38	41	44	47	50	52	57	63	73
	Standard High Limit	260	300	340	380	410	440	470	500	520	570	630	730
DN 40	Standard Low Limit	31	38	44	48	53	57	60	64	67	73	82	94
	Standard High Limit	310	380	440	480	530	570	600	640	670	730	820	940
DN 50	Standard Low Limit	52	63	73	81	88	95	101	107	112	122	136	157
	Standard High Limit	520	630	730	810	880	950	1010	1070	1120	1220	1360	1570
DN 65	Standard Low Limit	90	106	121	134	146	158	168	178	187	204	227	261
	Standard High Limit	900	1060	1210	1340	1460	1580	1680	1780	1870	2040	2270	2610
DN 80	Standard Low Limit	122	148	170	188	205	221	235	249	261	285	318	365
	Standard High Limit	1220	1480	1700	1880	2050	2210	2350	2490	2610	2850	3180	3650
DN 100	Standard Low Limit	175	212	242	269	293	315	336	355	374	408	454	522
	Standard High Limit	1750	2120	2420	2690	2930	3150	3360	3550	3740	4080	4540	5220
DN 125	Standard Low Limit	262	318	363	404	440	473	504	533	561	612	681	783
	Standard High Limit	2620	3180	3630	4040	4400	4730	5040	5330	5610	6120	6810	7830
DN 150	Standard Low Limit	300	423	484	538	596	631	672	711	747	815	908	1044
	Standard High Limit	3000	4230	4840	5380	5960	6310	6720	7110	7470	8150	9080	10440
DN 200	Standard Low Limit	700	846	969	1076	1173	1261	1344	1421	1494	1630	1815	2088
	Standard High Limit	7000	8460	9690	10760	11730	12610	13440	14210	14940	16300	18150	20880
DN 250	Standard Low Limit	1050	1269	1453	1641	1759	1892	2016	2132	2241	2245	2722	3132
	Standard High Limit	10500	12690	14530	16410	17590	18920	20160	21320	22410	22450	27220	31320
DN 300	Standard Low Limit	1750	2116	2422	2690	2932	3153	3369	3553	3736	4076	4536	5220
	Standard High Limit	17500	21160	24220	26900	29320	31530	33690	35530	37360	40760	45360	52200

3. 과포화증기 유량 범위표 (The quality flow range of superheated steam)

구경 Size (mm)	Low Limit Flow (kg/h)	High Limit Flow (kg/h)
25	$13.1\sqrt{P}$	$131\sqrt{P}$
32	$23\sqrt{P}$	$184\sqrt{P}$
40	$26.5\sqrt{P}$	$265\sqrt{P}$
50	$49.4\sqrt{P}$	$494\sqrt{P}$
65	$82.3\sqrt{P}$	$823\sqrt{P}$
80	$115.3\sqrt{P}$	$1153\sqrt{P}$
100	$164.7\sqrt{P}$	$1647\sqrt{P}$
125	$247.1\sqrt{P}$	$2471\sqrt{P}$
150	$329.4\sqrt{P}$	$3294\sqrt{P}$
200	$658.8\sqrt{P}$	$6588\sqrt{P}$
250	$988.2\sqrt{P}$	$9882\sqrt{P}$
300	$1647\sqrt{P}$	$16470\sqrt{P}$

접지 방법

CONNECTION AND GROUNDING BETWEEN THE SENSOR AND PIPE

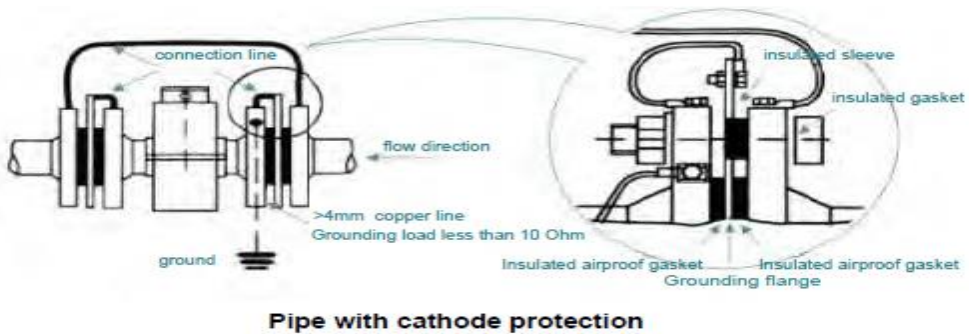
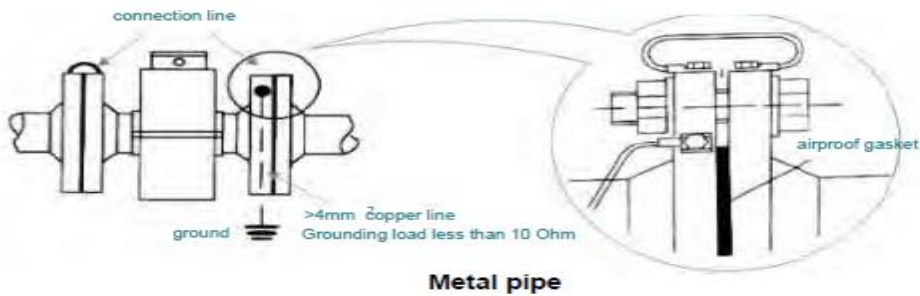

Order Code - KC-7760 Series (볼텍스유량계)

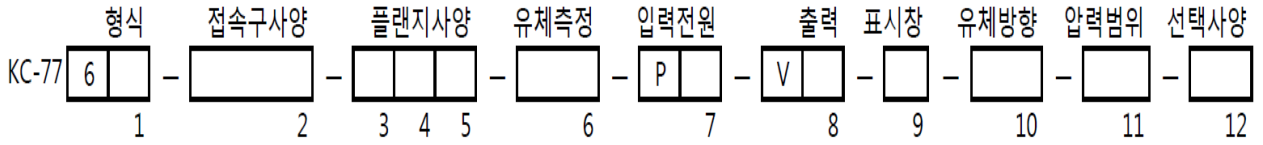

유량변환기 구조(structure type)	Code 1
일체형 (Integral)	1
분리형 (Remote)	2
고온용 (High Temp.)	3
온압 보정형	4
본질안전방폭 (Ex is IIC T6)	5
Agency approved, customer specified	W

측정유체 (Measured Medium)	Code 6
Liquid	1
Common Gas	2
Saturated Steam	3
Superheated Steam	4
Others	5
Agency approved, customer specified	W

압력 범위	Code 11
1.6 Mpa	1
2.5 Mpa	2
4.0 Mpa	3

선택사양	Code 12
Agency approved, customer specified	W

접속구 규격 (Connection Mode)	Code 2
DIN Flange	D
ANSI Flange	A
JIS Flange	J
Sanitary Clamp	S
Flange Card Installed	FC
Agency approved, customer specified	W

입력전원	Code 7
DC 24 V ±10 %, 100 mA	2
Agency approved, customer specified	W

출력	Code 8
Pulse & 4-20mA DC	1
RS-485	2
Agency approved, customer specified	W

접속구 사양	Code 3,4,5		
	Size	DIN	150 lb JIS 10k
1/2" (DN15)	D2	F2	J2
3/4" (DN20)	D3	F3	J3
1" (DN25)	D4	F4	J4
1-1/4" (DN32)	D5	F5	J5
1-1/2" (DN40)	D6	F6	J6
2" (DN50)	D7	F7	J7
2-1/2" (DN65)	D8	F8	J8
3" (DN80)	D9	F9	J9
4" (DN100)	D11	F11	J11
5" (DN150)	D12	F12	J12
6" (DN150)	D13	F13	J13
8" (DN200)	D15	F15	J15
10" (DN250)	D16	F16	J16
12" (DN300)	D17	F17	J17
Agency approved, customer specified	W		

표시창	Code 9
No Readout	NR
Digital Display (Flow & Total)	DD
Agency approved, customer specified	W

유체방향	Code 10
Horizontal Left to Right or Vertical UP	1
Horizontal Right to Left or Vertical Down	2
Agency approved, customer specified	W



Golden Rules

• GOLDEN RULES

www.goldenrules.co.kr

기체 & 액체 & 스팀용
질량 & 토탈유량계
전문 제조

전국 대리점

Certified in accordance with

KC Q ISO 9001 : 2015

KC Q ISO 14001 : 2015

 (주)골든룰