



RHM30L

Coriolis Mass Flow Meter for Plant and Loading Flows

사양

- Standard 압력 798 bar (11574 psi)
- 온도 범위 : -196 ~ 350°C (-320 ~ 662°F)
- 질량 유량 정밀도 0.15%
- 밀도 정밀도 0.5%
- 재현성 0.05%
- 일반 유량 측정 범위 750 ~ 7.5 kg/min
- 5 kg/min 까지의 낮은 유량도 정확하게 측정 가능
- 유일한 비틀림 기준진동 시스템
- 고객맞춤형 connection 제작 가능
- 작은 공간에 적합한 소형 디자인
- 방폭 지역 사용 인증 완료
- Stainless Steel 316 Ti 외함 가능
- 유지보수가 쉬운 분리형 manifold connection
- 분리형 및 소형의 트랜스미터

적용

- 일반 유량 측정
- Plant Balance
- Additive Dosing
- High Temperature Fluids
- Viscous Fluids
- Mixing, Blending, Batching (정량 제어)
- Package and Container Filling

이점

- 비틀림 진동자 디자인은 외란 영향을 적게 받아 안정적이고 탁월한 측정이 보장 된다.
- 외부 노이즈 및 진동에 영향을 받지 않는다.
- 배관 압력 변화에 민감하지 않다.
- 견고하고 두꺼운 센서 튜브는 안전한 운전 성능 보장
- 비틀림 기준진동으로 기계적인 스트레스 영향이 적어 센서의 내구성 보장
- 고성능 (goldline) 센서 선정 가능

RHM30L General Specifications

Nominal Max Flow Range:	Parallel/dual path measurement tube versions: 750 kg/min (1653.5 lb/min) Serial/single path measurement tube versions: 375 kg/min (826.7 lb/min)
Density Range:	5 to 5000 kg/m ³ (0.31 to 312 lb/ft ³)
Temperature Range:	5 temperature range options cover temperatures from -196°C to 350°C (-320°F to 662°F)
Pressure Ratings:	Dependent upon material
Electrical Connection:	Cable entry M25 x 1.5 (standard) M20 x 1.5, ½" NPT, ¾" NPT (optional) Max cable length to remote RHE transmitter 100m (330 ft)
Sensor Housing Materials:	1.4301 / 304 stainless steel (standard), 1.4571 / 316Ti stainless steel (optional) Epoxy coated aluminium electrical box (standard), 1.4571 / 316Ti stainless steel (optional)
Enclosure Type:	Protection class IP 65. Optional IP 66 / NEMA 4X
Material of Wetted Parts:	Sensors are available in a variety of standard and custom materials to suit a wide range of pressure ratings and chemical compatibility requirements. See the pressure ratings listing in this document for further details
Finishes:	ANSI flange finish: AARH 125 to 250 µm, Ra 3.2 to 6.3 µm
Certifications and Approvals:	ATEX approval Zone 0: Ex II 1 G Ex ia IIC T1-T6 Ga ATEX rating Zone 2: Ex II 3 G Ex nA IIC T1-T6 Gc CSA USA-Canada, Class I, Div. 1, Groups A, B, C, D PED according to 97/23/EC Module A1 or Module B + C1 (as required by application)
Documentation:	All sensors are supplied with a traceable calibration certificate. Optional documentation items available: - Traceable material certificates - Certificates of origin and conformity - Welding - NACE - Quality - Production and manufacturing procedures Other documentation to client requirements available
Proof Testing:	Hydrotest, dye penetrant, x-ray, PMI
Options:	Enclosure heating matrix for high temperature applications

Transmitter Range



RHE45



RHE21



RHE26



RHE27



RHE28

Any Rheonik Mass Flow Transmitter model can be combined with an RHM30 sensor to provide an overall mass flow measurement system to suit any requirement. Rheonik Coriolis transmitters are designed for process, industrial and OEM applications. Together they offer a tremendous range of options for system designers and end users alike.

RHM30L Measurement Performance

Standard Calibration		
Flow Rate		Uncertainty
kg/min	lb/min	in % of reading
750	1653	0.20
500	1102	0.20
100	220	0.20
35	77.2	0.20
15	33.1	0.50

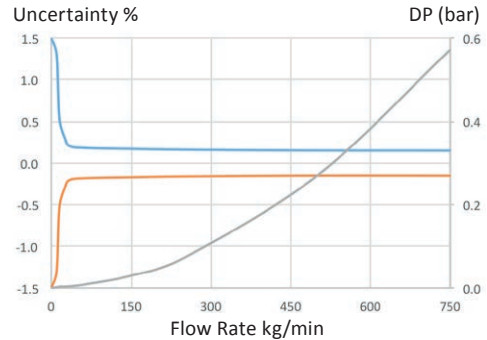

Goldline Calibration*		
Flow Rate		Uncertainty
kg/min	lb/min	in % of reading
600	1323	0.15
300	661	0.15
150	331	0.15
100	220	0.15
60	132	0.15

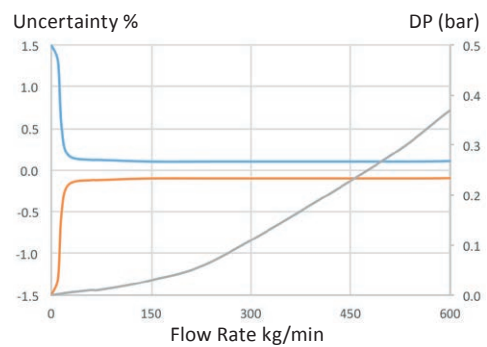

Low Flow Calibration*		
Flow Rate		Uncertainty
kg/min	lb/min	in % of reading
750	1653	0.20
500	1102	0.20
35	77.2	0.20
15	33.1	0.50
10	22	0.60

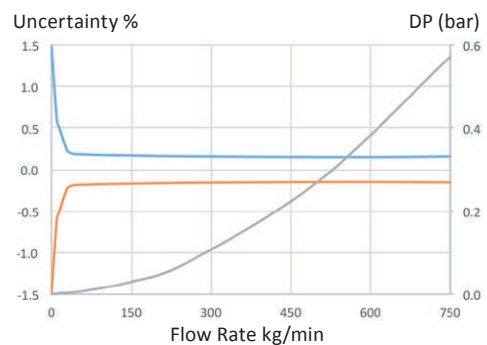

*Goldline and Low Flow Calibration is not available with all configurations of the RHM30. Please check with factory.

Mass Flow Calibration Options	
A	50:1 Standard Calibration – 0.5% Uncertainty between 750 and 15 kg/min
B	20:1 Standard Calibration – 0.2% Uncertainty between 750 and 35 kg/min
G	10: 1 Goldline Calibration – 0.15% Uncertainty between 600 and 60 kg/min
Z	Low Flow Calibration – 0.2% Uncertainty between 35 and 750 kg/min, 0.5% between 10 and 35 kg/min

- *Uncertainty of reading (incl. zero drift) stated at reference condition of: H₂O, 18-24°C (66 - 76°F), 1 – 3 bar (15 – 45 psi) when installed according to field manual*
- *Pressure drop indications are based upon H₂O flowing in a meter with P1 pressure rating and PM0 (parallel measuring tubes with manifold block) construction*
- *Serial path versions offer the same accuracy performance at half the flow (Nominal max. flow range of serial versions = 375 kg/min). Pressure drop will be greater*
- *For customized calibration range or uncertainty levels, please consult factory*

Flow Measurement Repeatability

Standard ± 0.1% of rate
Goldline ± 0.05% of rate

Density Measurement Performance (liquids)

Standard 2 point calibration ±1% of value
Optional 3 point calibration ±0.5% of value
Gas density – depends upon pressure

Temperature

Better than ± 1°C

RHM30L Pressure Ratings

The maximum pressure (P_{max}) of a sensor is determined by its lowest rated part. The lowest rated part can be either the measuring tube (P_{max} indicated below), the construction type (P_{max} indicated in the Part Number Code section, last page) or the process connection (for P_{max} see published standards or manufacturer information).

RHM30L Measurement Tube Pressure Ratings

Pressure Code	Material Code	Material	P_{max}				
			bar	psi		°C	°F
P1 (std.)	M1 (std.)	1.4571 (316Ti) UNS S31635	137	1987	@	50	122
			123	1784	@	120	248
			106	1537	@	210	410
			89	1291	@	350	662
P1	M3	2.4602 (Alloy C22) UNS N06022	271	3931	@	50	122
			239	3466	@	120	248
			204	2959	@	210	410
			170	2466	@	350	662
P1	M4*	Tantalum UNS R05200	71	1030	@	50	122
			55	798	@	120	248
			44	638	@	210	410
P2	M1 (std.)	1.4571 (316Ti) UNS S31635	334	5105	@	50	122
			299	4351	@	120	248
			258	3626	@	210	410
			217	3046	@	350	662
P2	10**	1.4410 (Super Duplex) UNS S32750	574	8325	@	50	122
			503	7295	@	120	248
			455	6599	@	210	410
P2	62**	1.4462 (Duplex) UNS S31803	458	6643	@	50	122
			401	5816	@	120	248
			351	5091	@	210	410
P3	M1 (std.)	1.4571 (316Ti) UNS S31635	490	7107	@	50	122
			438	6353	@	120	248
			378	5482	@	210	410
			319	4627	@	350	662
P3	10**	1.4410 (Super Duplex) UNS S32750	798	11574	@	50	122
			700	10153	@	120	248
			633	9181	@	210	410
P3	62**	1.4462 (Duplex) UNS S31803	637	9239	@	50	122
			558	8093	@	120	248
			489	7092	@	210	410

*Only with T1, TA, T2 temperature range (note max. operating temp. is 150°C) and PF0 construction type (max. ANSI 300/PN40).

**Only with T1, TA, T2 temperature range (note min. temp. is -40°C) and PF0 construction type.

Other Materials

Additional/custom wetted materials (Inconel, Monel, 304 stainless steel, others) may be possible for chemical compatibility, lower pressure drop, abrasion allowance, other application specific requirements.

Contact factory with specification for assessment and availability.

RHM30L Mechanical Construction

PM0: Parallel measuring tubes with flange connection and removable manifold with PTFE seals

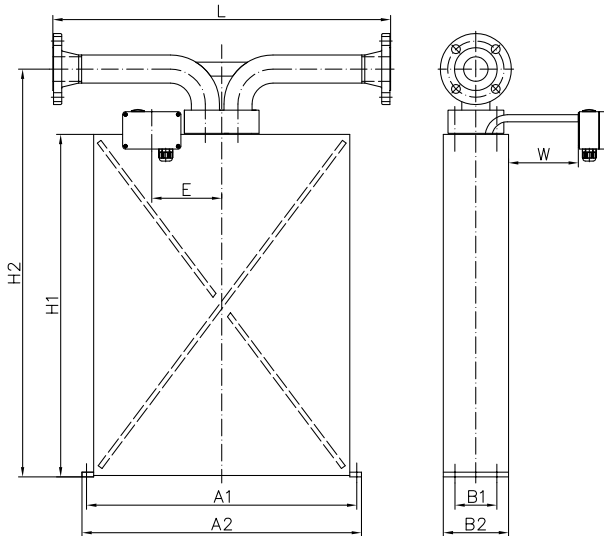

Process Connection	Face to face length (L)		Order Code
	mm	in	
ANSI 2" 150# RF	725	28.54	A1
ANSI 2" 300# RF	725	28.54	A2
ANSI 2" 600# RF	725	28.54	A3
ANSI 2" 600# RTJ	725	28.54	R5
DIN DN50/PN40	725	28.54	D1
DIN DN50/PN100	725	28.54	D2
JIS B 2220 RF 10k 50A (2")	725	28.54	J1
JIS B 2220 RF 20k 50A (2")	725	28.54	J2

PF0: Seal-less parallel measuring tube construction with flange connections

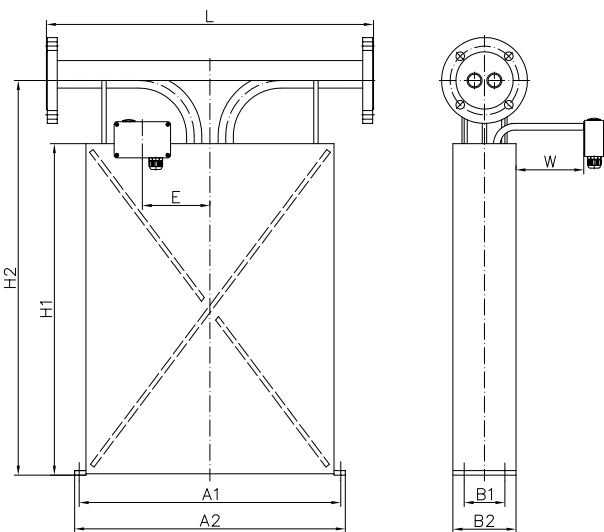

Process Connection	Face to face length (L)		Order Code
	mm	in	
ANSI 3" 150# RF	725	28.54	F1
ANSI 3" 300# RF	725	28.54	F2
ANSI 3" 600# RF	725	28.54	F3
ANSI 3" 900# RF	725	28.54	A4
ANSI 3" 1500# RF	725	28.54	AA
ANSI 3" 2500# RF	900	35.43	A8
ANSI 4" 150# RF	725	28.54	L1
ANSI 4" 900# RF	725	28.54	J3
ANSI 2" 1500# RTJ	725	28.54	R4
ANSI 3" 300# RTJ	725	28.54	R0
ANSI 3" 600# RTJ	725	28.54	R1
ANSI 3" 900# RTJ	725	28.54	R2
ANSI 3" 1500# RTJ	725	28.54	R6
ANSI 3" 2500# RTJ	900	35.43	R3
DIN DN80/PN40	725	28.54	C1
DIN DN80/PN100	725	28.54	C2
DIN DN80/PN160	725	28.54	C5
DIN DN80/PN320	725	28.54	C4
Grayloc 4" GR23 Hub	725	28.54	H1

The sensor is manufactured with two internal measurement tubes arranged side by side. In parallel or dual path sensors, these tubes are connected in parallel and the flowing fluid is split equally between them. For customization of face to face length and/or special fittings other than the ones listed on this page, please consult factory.
Note that larger diameter flange process connections are always possible.

Common Dimensions

A1 = 580 mm (22.83 in) A2 = 600 mm (23.62 in) B1 = 90 mm (3.54 in) B2 = 140 mm (5.51 in) H1 = 735 mm (28.94 in) H2 = 875 mm (34.45 in)
 E = 150 mm (5.91 in) W = 150 mm (5.91 in)
 Electrical box: std. = 125 x 80 x 58 mm (4.92 x 3.15 x 2.28 in), RHE16 compact = 120 x 120 x 80 mm (4.72 x 4.72 x 3.15 in)

For weights and packaging dimensions please see last page of the Mechanical Construction section.

RHM30L Mechanical Construction

SFO: Seal-less serial measuring tube construction with sanitary connections*

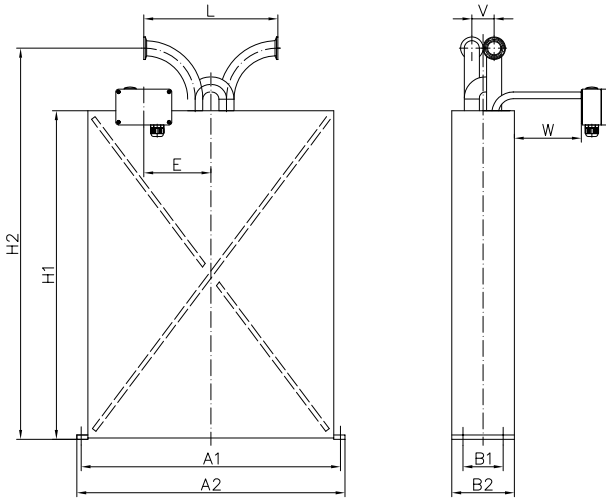

Process Connection	Face to face length (L)		Order Code
	mm	in	
Sanitary 1½" Triclamp, DIN 32676 (P _{max} = 17.2 bar (249.5 psi) @ 120°C (248°F))	300	11.81	S1
Sanitary NW32, DIN 11851 (P _{max} = 40 bar (580 psi) @ 120°C (248°F))	300	11.81	S2

SFO: Seal-less serial measuring tube construction with flange connections*

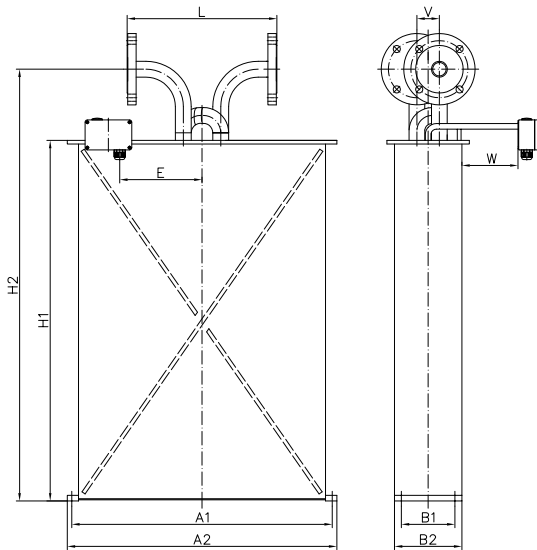

Process Connection	Face to face length (L)		Order Code
	mm	in	
ANSI 3" 150# RF	300	11.81	F1
ANSI 3" 300# RF	300	11.81	F2
ANSI 3" 600# RF	300	11.81	F3
ANSI 3" 900# RF	725	28.54	A4
ANSI 3" 150# RTJ	300	11.81	F1
ANSI 3" 300# RTJ	300	11.81	F2
ANSI 3" 600# RTJ	300	11.81	F3
ANSI 3" 900# RTJ	725	28.54	A4
ANSI 3" 1500# RTJ	725	28.54	AA
ANSI 4" 150# RTJ	300	11.81	L1
ANSI 2" 1500# RTJ	725	28.54	R4
ANSI 3" 900# RTJ	725	28.54	R2
ANSI 3" 300# RTJ	725	28.54	R0
ANSI 3" 600# RTJ	725	28.54	R1
ANSI 3" 1500# RTJ	725	28.54	R6
ANSI 4" 900# RTJ	725	28.54	J3
DIN DN80/PN40	300	11.81	C1
DIN DN80/PN100	300	11.81	C2
DIN DN80/PN160	300	11.81	C5

The sensor is manufactured with two internal measurement tubes arranged side by side. In serial or single path sensors, the tubes are connected end to end creating a single path through which all fluid flows. For customization of face to face length and/or special fittings other than the ones listed on this page, please consult factory.
Note that larger diameter flange process connections are always possible.

Common Dimensions

A1 = 580 mm (22.83 in) A2 = 600 mm (23.62 in) B1 = 90 mm (3.54 in) B2 = 140 mm (5.51 in) H1 = 735 mm (28.94 in) H2 = 875 mm (34.45 in)
 E = 150 mm (5.91 in) V = 50 mm (1.97 in) W = 150 mm (5.91 in)
 Electrical box: std. = 125 x 80 x 58 mm (4.92 x 3.15 x 2.28 in), RHE16 compact = 120 x 120 x 80 mm (4.72 x 4.72 x 3.15 in)

*SFO meters are constructed with offset inlet/outlet ports. Consideration should be given to the offset (dimension V) when planning installation.

Weights and Shipping Dimensions

Typical weight for PM0/PF0 construction meter with 150# flanges: approx. 58 kg (128 lb).
 Typical weight for SFO construction meter with 150# flanges: approx. 53 kg (117 lb).
 RHM30 meters ship in a wooden crate (to ISPM 15). Typical dimensions approx. 125 x 85 x 60 cm (49 x 34 x 24 in).
 Typical gross shipping weight example: RHM30 PM0/PF0 construction sensor with 150# flanges c/w RHE08 transmitter approx. 115 kg (254 lb).