



RHM15L

Process Sized Coriolis Mass Flow Meter

사양

- Standard 압력 882 bar (12792 psi)
- 온도 범위 : -196 ~ 350°C (-320 ~ 662°F)
- 질량 유량 정밀도 0.10% (골드라인 기준)
- 재현성 0.05%
- 일반 유량 측정 범위 2 ~ 200 kg /min
- 1 kg/min 까지의 낮은 유량도 정확하게 측정 가능
- 유일한 비틀림 기준진동 시스템
- 고객 맞춤형 connection 제작 가능
- 작은 공간에 적합한 소형 디자인
- 방폭 지역 사용 인증 완료
- Stainless Steel 316 Ti 외함 가능
- 유지보수가 쉬운 분리형 manifold connection
- 분리형 및 소형의 트랜스미터

적용

- 일반 유량 측정
- Plant Balance
- Additive Dosing
- Mixing 및 Batching (정량제어)
- Package and Container Filling

이점

- 비틀림 진동자 디자인은 외란 영향을 적게 받아 안정적이고 탁월한 측정이 보장 된다.
- 외부 노이즈 및 진동에 영향을 받지 않는다.
- 배관 압력 변화에 민감하지 않다.
- 견고하고 두꺼운 센서 튜브는 안전한 운전 성능 보장
- 비틀림 기준진동으로 기계적인 스트레스 영향이 적어 센서의 내구성 보장
- 고성능(goldline)센서 선정 가능

RHM15L General Specifications

Nominal Max Flow Range:	Parallel/dual path measurement tube versions: 200 kg/min (440.9 lb/min) Serial/single path measurement tube versions: 100 kg/min (220.5 lb/min)
Density Range:	5 to 5000 kg/m ³ (0.31 to 312 lb/ft ³)
Temperature Range:	5 temperature range options cover temperatures from -196°C to 350°C (-320°F to 662°F)
Pressure Ratings:	Dependent upon material
Electrical Connection:	Cable entry M25 x 1.5 (standard) M20 x 1.5, ½" NPT, ¾" NPT (optional) Max cable length to remote RHE transmitter 100m (330 ft)
Sensor Housing Materials:	1.4301 / 304 stainless steel (standard), 1.4571 / 316Ti stainless steel (optional) Epoxy coated aluminium electrical box (standard), 1.4571 / 316Ti stainless steel (optional)
Enclosure Type:	Protection class IP 65. Optional IP 66 / NEMA 4X
Material of Wetted Parts:	Sensors are available in a variety of standard and custom materials to suit a wide range of pressure ratings and chemical compatibility requirements. See the pressure ratings listing in this document for further details
Finishes:	ANSI flange finish: AARH 125 to 250 µin, Ra 3.2 to 6.3 µm
Certifications and Approvals:	ATEX approval Zone 0: Ex II 1 G Ex ia IIC T1-T6 Ga ATEX rating Zone 2: Ex II 3 G Ex nA IIC T1-T6 Gc CSA USA-Canada, Class I, Div. 1, Groups A, B, C, D PED according to 97/23/EC Art.3 (3) Sound Engineering Practice (SEP)
Documentation:	All sensors are supplied with a traceable calibration certificate. Optional documentation items available: - Traceable material certificates - Certificates of origin and conformity - Welding - NACE - Quality - Production and manufacturing procedures Other documentation to client requirements available
Proof Testing:	Hydrotest, dye penetrant, x-ray, PMI
Options:	Enclosure heating matrix for high temperature applications

Transmitter Range



RHE45



RHE21



RHE26



RHE27



RHE28

Any Rheonik Mass Flow Transmitter model can be combined with an RHM15 sensor to provide an overall mass flow measurement system to suit any requirement. Rheonik Coriolis transmitters are designed for process, industrial and OEM applications. Together they offer a tremendous range of options for system designers and end users alike.

RHM15L Measurement Performance

Standard Calibration		
Flow Rate		Uncertainty
kg/min	lb/min	in % of reading
200	441	0.20
10	220	0.20
50	110	0.20
10	22	0.20
4.0	8.8	0.50

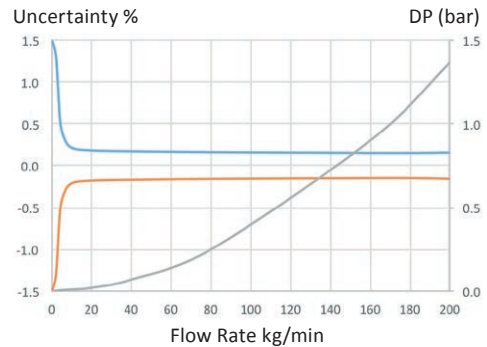

Goldline Calibration*		
Flow Rate		Uncertainty
kg/min	lb/min	in % of reading
150	331	0.10
75	165	0.10
50	110	0.10
15	33.1	0.10
7.5	16.5	0.12

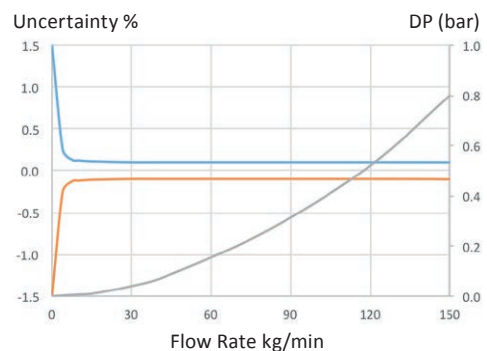

Low Flow Calibration*		
Flow Rate		Uncertainty
kg/min	lb/min	in % of reading
80	176	0.20
50	110	0.20
15	33	0.20
4.0	8.8	0.20
2.0	4.4	0.60

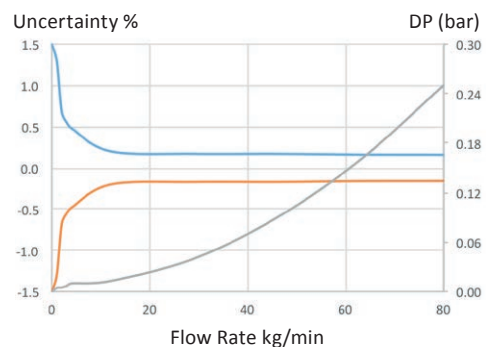

*Goldline and Low Flow Calibration is not available with all configurations of the RHM15. Please check with factory.

Mass Flow Calibration Options	
A	50:1 Standard Calibration – 0.5% Uncertainty between 200 and 4 kg/min
B	20:1 Standard Calibration – 0.2% Uncertainty between 200 and 10 kg/min
C	1:20 Calibration – 0.2% Uncertainty between 4 and 80 kg/min
G	20:1 Goldline Calibration – 0.12% Uncertainty between 150 and 7.5 kg/min
P	10:1 Goldline Calibration – 0.10% Uncertainty between 150 and 15 kg/min
1	Low Flow Calibration – 0.2% Uncertainty between 4 and 80 kg/min, 0.6% between 2 and 4 kg/min

- *Uncertainty of reading (incl. zero drift) stated at reference condition of: H₂O, 18-24°C (66-76°F), 1-3 bar (15-45 psi) when installed according to field manual*
- *Pressure drop indications are based upon H₂O flowing in a meter with P1 pressure rating and PM0 (parallel measuring tubes with manifold block) construction*
- *Serial path versions offer the same accuracy performance at half the flow (Nominal max. flow range of serial versions = 100 kg/min). Pressure drop will be greater*
- *For customized calibration range or uncertainty levels, please consult factory*

Flow Measurement Repeatability

Standard ± 0.1% of rate
Goldline ± 0.05% of rate

Density Measurement Performance (liquids)

Standard 2 point calibration ±1% of value
Optional 3 point calibration ±0.5% of value
Gas density – depends upon pressure

Temperature

Better than ± 1°C

RHM15L Pressure Ratings

The maximum pressure (P_{max}) of a sensor is determined by its lowest rated part. The lowest rated part can be either the measuring tube (P_{max} indicated below), the construction type (P_{max} indicated in the Part Number Code section, last page) or the process connection (for P_{max} see published standards or manufacturer information).

RHM15L Measurement Tube Pressure Ratings

Pressure Code	Material Code	Material	P_{max}				
			bar	psi	@	°C	°F
P1 (std.)	M1 (std.)	1.4571 (316Ti) UNS S31635	165	2393	@	50	122
			150	2176	@	120	248
			127	1842	@	210	410
			107	1552	@	350	662
P1	M3	2.4602 (Alloy C22) UNS N06022	228	3307	@	50	122
			201	2915	@	120	248
			172	2495	@	210	410
			143	2074	@	350	662
P1	M4*	Tantalum UNS R05200	86	1247	@	50	122
			66	957	@	120	248
			53	769	@	210	410
P1	10**	1.4410 (Super Duplex) UNS S32750	395	5729	@	50	122
			346	5018	@	120	248
			313	4540	@	210	410
P1	62**	1.4462 (Duplex) UNS S31803	315	4569	@	50	122
			276	4003	@	120	248
			242	3510	@	210	410
P2	M1 (std.)	1.4571 (316Ti) UNS S31635	352	5105	@	50	122
			300	4351	@	120	248
			250	3626	@	210	410
			210	3046	@	350	662
P2	M3	2.4602 (Alloy C22) UNS N06022	540	7832	@	50	122
			477	6918	@	120	248
			407	5903	@	210	410
			339	4917	@	350	662
P2	10**	1.4410 (Super Duplex) UNS S32750	882	12792	@	50	122
			773	11211	@	120	248
			699	10138	@	210	410
P2	62**	1.4462 (Duplex) UNS S31803	704	10211	@	50	122
			617	8949	@	120	248
			540	7832	@	210	410
P3	M1 (std.)	1.4571 (316Ti) UNS S31635	540	7832	@	50	122
			450	6527	@	120	248
			350	5076	@	210	410
			300	4351	@	350	662

*Only with T1, TA, T2 temperature range (note max. operating temp. is 150°C) and PFO construction type (max. ANSI 300/PN40).

**Only with T1, TA, T2 temperature range (note min. temp. is -40°C) and PFO construction type.

Other Materials

Additional/custom wetted materials (Inconel, Monel, 304 stainless steel, others) may be possible for chemical compatibility, lower pressure drop, abrasion allowance, other application specific requirements.

Contact factory with specification for assessment and availability.

RHM15L Mechanical Construction

PM0/SM0: Serial or parallel measuring tubes with flange connection and removable manifold with PTFE seals

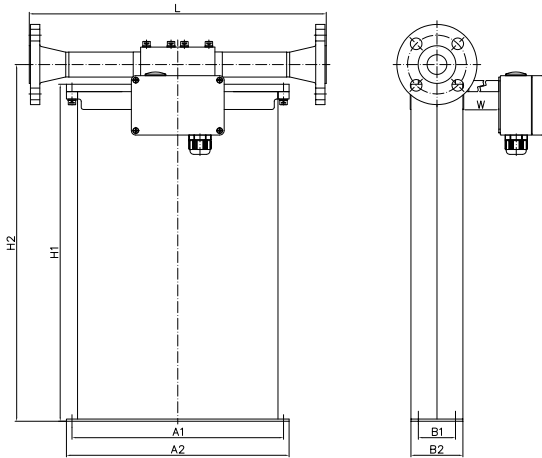

Process Connection	Face to face length (L)		Order Code
	mm	in	
ANSI 1" 150# RF	400	15.75	A1
ANSI 1" 300# RF	400	15.75	A2
ANSI 1" 600# RF	400	15.75	A3
ANSI 1" 1500# RF	450	17.72	A6
ANSI 1" 1500# RTJ	450	17.72	R3
DIN DN25/PN16	400	15.75	D4
DIN DN25/PN40	400	15.75	D1
DIN DN25/PN100	400	15.75	D2
JIS RF 10k 25A (1")	400	15.75	J1
JIS RF 20k 25A (1")	400	15.75	J2

Type removable manifold with PTFE seals and thread connection

PM0/SM0/PH0: Serial or parallel measuring tubes with female thread connection and removable manifold with PTFE seals

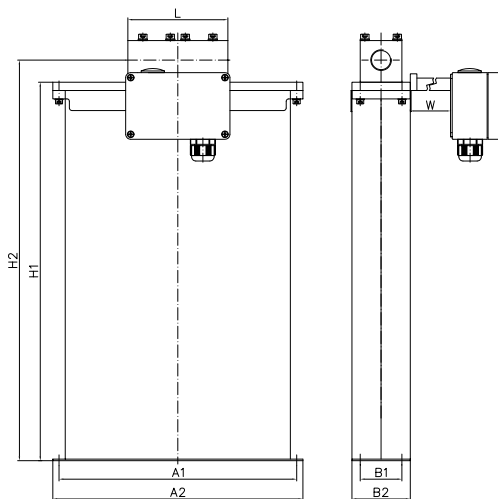

Process Connection	Face to face length (L)		Order Code
	mm	in	
Female Thread G 3/4"	120	4.72	G1
Female Thread 3/4" NPT	120	4.72	N1

The sensor is manufactured with two internal measurement tubes arranged side by side. In parallel or dual path sensors, these tubes are connected in parallel and the flowing fluid is split equally between them. In serial or single path sensors, the tubes are connected end to end creating a single path through which all fluid flows. For customization of face to face length and/or special fittings other than the ones listed on this page, please consult factory. *Note that larger diameter flange process connections are always possible.*

Common Dimensions

A1 = 285 mm (11.22 in) A2 = 300 mm (11.81 in) B1 = 50 mm (1.97 in) B2 = 70 mm (2.76 in) H1 = 454 mm (17.87 in) H2 = 481 mm (18.94 in)

W: temp. range T1, TA = 0 mm (0 in), temp. range T2 = 150 mm (5.91 in)

Electrical box: std. = 125 x 80 x 58 mm (4.92 x 3.15 x 2.28 in), RHE16 compact = 120 x 120 x 80 mm (4.72 x 4.72 x 3.15 in)

For weights and packaging dimensions please see last page of the Mechanical Construction section.

RHM15L Mechanical Construction

PFO: Seal-less parallel measuring tube construction with flange connections

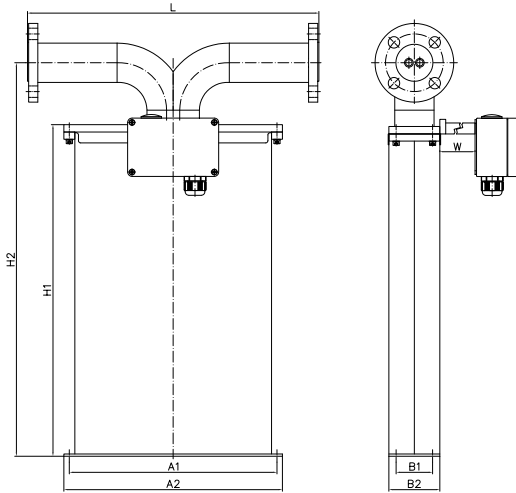

Process Connection	Face to face length (L)		Order Code
	mm	in	
ANSI 1½" 150# RF	400	15.75	F1
ANSI 1½" 300# RF	400	15.75	F2
ANSI 1½" 600# RF	400	15.75	F3
ANSI 1½" 1500# RF	400	15.75	F5
ANSI 1½" 2500# RF	450	17.72	F4
ANSI 1½" 1500# RTJ	400	15.75	R4
ANSI 1½" 2500# RTJ	450	17.72	R5
ANSI 2" 1500# RTJ	500	19.69	R1
DIN DN40/PN40	400	15.75	C1
DIN DN40/PN100	400	15.75	C2
DIN DN40/PN160	400	15.75	C4
JIS RF 10k 40A (1½")	400	15.75	J1
JIS RF 20k 40A (1½")	400	15.75	J2
Grayloc Hub 1½" GR11	400	15.75	H6
Grayloc Hub 2" GR11	400	15.75	H8
Grayloc Hub 2" GR14	400	15.75	H3

PFT: Seal-less parallel measuring tube construction with thread and compression fitting connections

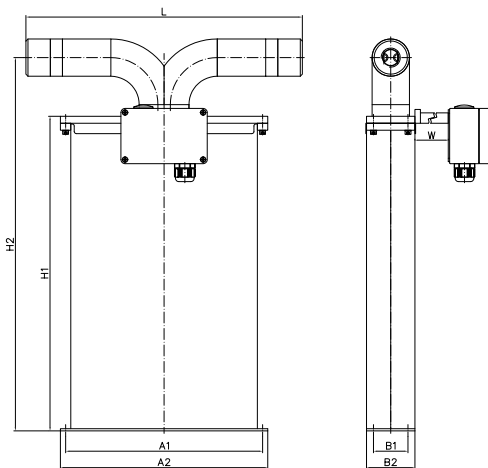

Process Connection	Face to face length (L)		Order Code
	mm	in	
Female Thread G ¾"	400	15.75	G1
Female Thread ¾" NPT	400	15.75	N1
Swagelok ¾" tube compression fitting (SS-1210-1-12W)	470	18.50	W1

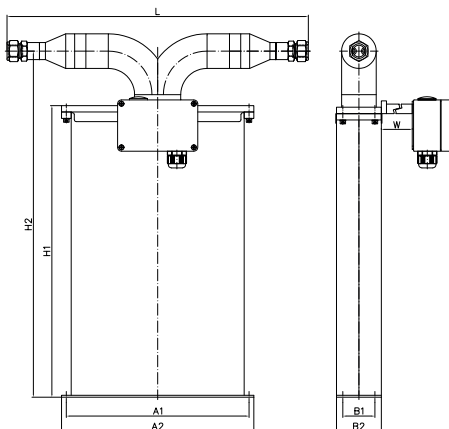

The sensor is manufactured with two internal measurement tubes arranged side by side. In parallel or dual path sensors, these tubes are connected in parallel and the flowing fluid is split equally between them. For customization of face to face length and/or special fittings other than the ones listed on this page, please consult factory.
Note that larger diameter flange process connections are always possible.

Common Dimensions

A1 = 285 mm (11.22 in) A2 = 300 mm (11.81 in) B1 = 50 mm (1.97 in) B2 = 70 mm (2.76 in) H1 = 454 mm (17.87 in) H2 = 540 mm (21.26 in)
 W: temp. range T1, TA = 0 mm (0 in), temp. range T2, T3, T4 = 150 mm (5.91 in)
 Electrical box: std. = 125 x 80 x 58 mm (4.92 x 3.15 x 2.28 in), RHE16 compact = 120 x 80 mm (4.72 x 3.15 in)

For weights and packaging dimensions please see last page of the Mechanical Construction section.

RHM15L Mechanical Construction

SFO: Seal-less serial measuring tube construction with sanitary connections*

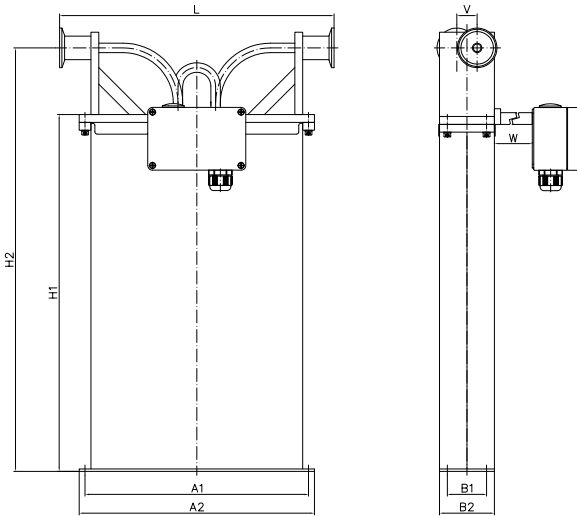

Process Connection	Face to face length (L)		Order Code
	mm	in	
Sanitary 1" Triclamp, DIN 32676	350	13.78	S0**
Sanitary NW20, DIN 11851	350	13.78	S2**

SFO: Seal-less serial measuring tube construction with flange connections*

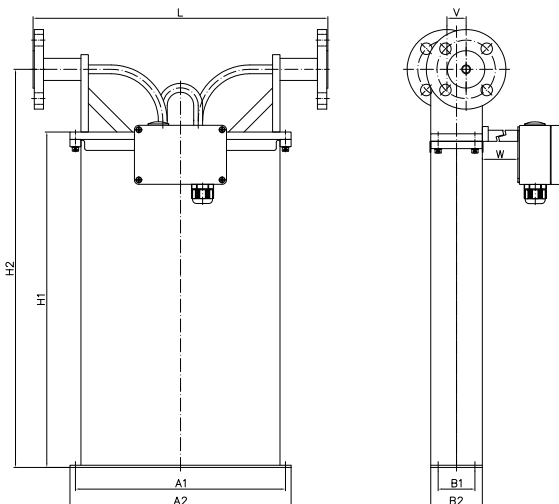

Process Connection	Face to face length (L)		Order Code
	mm	in	
ANSI 1½" 150# RF	400	15.75	F1
ANSI 1½" 300# RF	400	15.75	F2
DIN DN40/PN40	400	15.75	C1

The sensor is manufactured with two internal measurement tubes arranged side by side. In serial or single path sensors, the tubes are connected end to end creating a single path through which all fluid flows. For customization of face to face length and/or special fittings other than the ones listed on this page, please consult factory.
Note that larger diameter flange process connections are always possible.

Common Dimensions

A1 = 285 mm (11.22 in) A2 = 300 mm (11.81 in) B1 = 50 mm (1.97 in) B2 = 70 mm (2.76 in) H1 = 454 mm (17.87 in) H2 = 540 mm (21.26 in)
 V = 26 mm (1.02 in)

W: temp. range T1, TA = 0 mm (0 in), temp. range T2, T3, T4 = 150 mm (5.91 in)

Electrical box: std. = 125 x 80 x 58 mm (4.92 x 3.15 x 2.28 in), RHE16 compact = 120 x 120 x 80 mm (4.72 x 4.72 x 3.15 in)

* SFO meters are constructed with offset inlet/outlet ports. Consideration should be given to the offset (dimension V) when planning installation.

**P_{max} for sanitary fittings is 40 bar (580 psi) @120°C (248°F).

Weights and Shipping Dimensions

Typical weight for standard manifold construction (PM0/SM0) sensor with female threads: approx. 14 kg (31 lb).

Typical weight for standard seal-less construction (PF0/SFO) sensor with 150# flanges: approx. 16 kg (35 lb).

RHM15 sensors typically ship in a carton approx. 70 x 40 x 55 cm (27.6 x 15.7 x 21.7 in) complete with transmitter and cable.

Typical gross shipping weight example: RHM15 seal-less construction sensor with 150# flanges c/w RHE08 transmitter approx. 27 kg (60 lb).