



RHM80L

High Flow Coriolis Mass Flow Meter

사양

- Standard 압력 341 bar (4946 psi)
- 온도 범위 : -196 ~ 350°C (-320 ~ 662°F)
- 질량 유량 정밀도 0.15%
- 밀도 정밀도 0.5%
- 재현성 0.05%
- 일반 유량 측정 범위 200 ~ 8000 kg/min
- 130 kg/min 까지의 낮은 유량도 정확하게 측정 가능
- 유일한 비틀림 기준진동 시스템
- 고객 맞춤형 connection 제작 가능
- 방폭 지역 사용 인증 완료
- Stainless Steel 316 Ti 외함 가능
- 분리형 및 소형의 트랜스미터

적용

- Terminal Transfer
- Asphalt/Bitumen and Other High Temperature Fluids
- Viscous Fluids
- Barge, Ship, Rail Car and Truck Filling

이점

- 비틀림 진동자 디자인은 외란 영향을 적게 받아 안정적이고 탁월한 측정이 보장 된다.
- 외부 노이즈 및 진동에 영향을 받지 않는다.
- 배관 압력 변화에 민감하지 않다.
- 견고하고 두꺼운 센서 튜브는 안전한 운전 성능 보장
- 비틀림 기준진동으로 기계적인 스트레스 영향이 적어 센서의 내구성 보장
- 고성능 (goldline) 센서 선정 가능

RHM80L General Specifications

Nominal Max Flow Range:	8000 kg/min (17637 lb/min)
Density Range:	5 to 5000 kg/m ³ (0.31 to 312 lb/ft ³)
Temperature Range:	5 temperature range options cover temperatures from -196°C to 350°C (-320°F to 662°F)
Pressure Ratings:	Dependent upon material
Electrical Connection:	Cable entry M25 x 1.5 (standard) M20 x 1.5, ½" NPT, ¾" NPT (optional) Max cable length to remote RHE transmitter 30m (98 ft). 100m (330ft) with optional high performance cable
Sensor Housing Materials:	1.4301 / 304 stainless steel (standard), 1.4571 / 316Ti stainless steel (optional) Epoxy coated aluminium electrical box (standard), 1.4571 / 316Ti stainless steel (optional)
Enclosure Type:	Protection Class IP 65. Optional IP 66 / NEMA 4X
Material of Wetted Parts:	Sensors are available in a variety of standard and custom materials to suit a wide range of pressure ratings and chemical compatibility requirements. See the pressure ratings listing in this document for further details
Finishes:	ANSI flange finish: AARH 125 to 250 µm, Ra 3.2 to 6.3 µm
Certifications and Approvals:	ATEX approval Zone 0: Ex II 1 G Ex ia IIC T1-T6 Ga ATEX rating Zone 2: Ex II 3 G Ex nA IIC T1-T6 Gc CSA USA-Canada, Class I, Div. 1, Groups A, B, C, D PED according to 97/23/EC Module A1 or Module B + C1 (as required by application)
Documentation:	All sensors are supplied with a traceable calibration certificate. Optional documentation items available: <ul style="list-style-type: none"> - Traceable material certificates - Certificates of origin and conformity - Welding - NACE - Quality - Production and manufacturing procedures Other documentation to client requirements available
Proof Testing:	Hydrotest, dye penetrant, x-ray, PMI
Options:	Enclosure heating matrix for high temperature applications

Transmitter Range



RHE45



RHE21



RHE26



RHE27



RHE28

Any Rheonik Mass Flow Transmitter model can be combined with an RHM80 sensor to provide an overall mass flow measurement system to suit any requirement. Rheonik Coriolis transmitters are designed for process, industrial and OEM applications. Together they offer a tremendous range of options for system designers and end users alike.

RHM80L Measurement Performance

Standard Calibration		
Flow Rate		Uncertainty
kg/min	lb/min	in % of reading
8000	17637	0.20
4000	8818	0.20
1000	2205	0.20
400	882	0.20
200	441	0.50

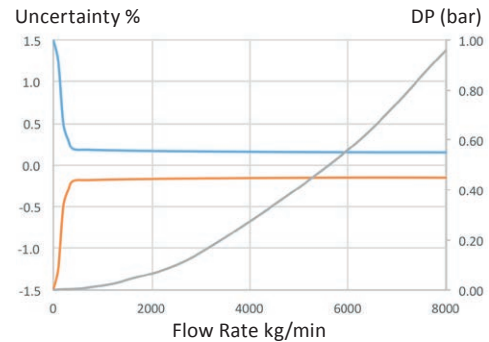

Goldline Calibration*		
Flow Rate		Uncertainty
kg/min	lb/min	in % of reading
6000	13228	0.15
4500	9921	0.15
3000	6614	0.15
1500	3307	0.15
600	1323	0.15

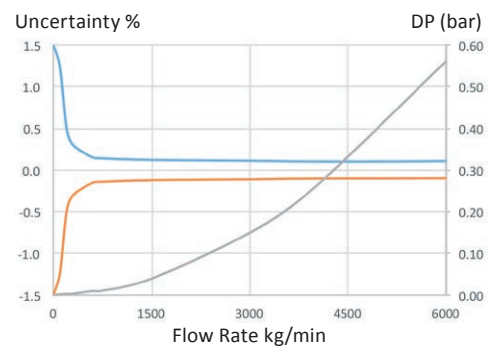

Low Flow Calibration*		
Flow Rate		Uncertainty
kg/min	lb/min	in % of reading
8000	17637	0.20
2000	4409	0.20
400	882	0.20
200	441	0.50
130	287	0.60

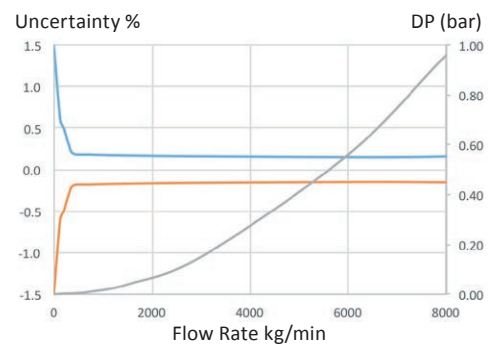

*Goldline and Low Flow Calibration is not available with all configurations of the RHM80. Please check with factory.

Mass Flow Calibration Options	
A	40:1 Standard Calibration – 0.5% Uncertainty between 8000 and 200 kg/min
B	20:1 Standard Calibration – 0.2% Uncertainty between 8000 and 400 kg/min
G	10:1 Goldline Calibration – 0.15% Uncertainty between 6000 and 600 kg/min
2	Low Flow Calibration – 0.2% Uncertainty between 8000 and 400 kg/min, 0.5% between 400 and 200 kg/min, 0.6% between 200 and 130 kg/min

- *Uncertainty of reading (incl. zero drift) stated at reference condition of: H₂O, 18-24°C (66-6°F), 1-3 bar (15-45 psi) when installed according to field manual*
- *Pressure drop indications are based upon H₂O flowing in a meter with P1 pressure rating*
- *For customized calibration range or uncertainty levels, please consult factory*

Flow Measurement Repeatability

Standard ± 0.1% of rate
Goldline ± 0.05% of rate

Density Measurement Performance (liquids)

Standard 2 point calibration ±1% of value
Optional 3 point calibration ±0.5% of value
Gas density – depends upon pressure

Temperature

Better than ± 1°C

RHM80L Pressure Ratings

The maximum pressure (P_{max}) of a sensor is determined by its lowest rated part. The lowest rated part is either the measuring tube (P_{max} indicated below) or the process connection (for P_{max} see published standards or manufacturer information).

RHM80L Measurement Tube Pressure Ratings

Pressure Code	Material Code	Material	P_{max}				
			bar	psi		°C	°F
P1 (std.)	M1 (std.)	1.4571 (316Ti) UNS S31635	104	1508	@	50	122
			93	1349	@	120	248
			80	1160	@	210	410
			67	972	@	350	662
P1	M3	2.4602 (Alloy C22) UNS N06022	141	2045	@	50	122
			125	1813	@	120	248
			106	1537	@	210	410
			89	1291	@	350	662
P1	10*	1.4410 (Super Duplex) UNS S32750	248	3597	@	50	122
			218	3162	@	120	248
			197	2857	@	210	410
P1	62*	1.4462 (Duplex) UNS S31803	198	2872	@	50	122
			174	2524	@	120	248
			152	2205	@	210	410
P2	M1 (std.)	1.4571 (316Ti) UNS S31635	165	2393	@	50	122
			148	2147	@	120	248
			127	1842	@	210	410
			107	1552	@	350	662
P2	10*	1.4462 (Duplex) UNS S31803	272	3945	@	50	122
			238	3452	@	120	248
			209	3031	@	210	410
P2	62*	1.4410 (Super Duplex) UNS S32750	341	4946	@	50	122
			299	4337	@	120	248
			270	3916	@	210	410

*Only with T1, TA, T2 temperature range (note min. temp. is -40°C).

Other Materials

Additional/custom wetted materials (Inconel, Monel, 304 stainless steel, others) may be possible for chemical compatibility, lower pressure drop, abrasion allowance, other application specific requirements.

Contact factory with specification for assessment and availability.

RHM80L Mechanical Construction

PFO: Seal-less parallel measuring tube construction with flange connections

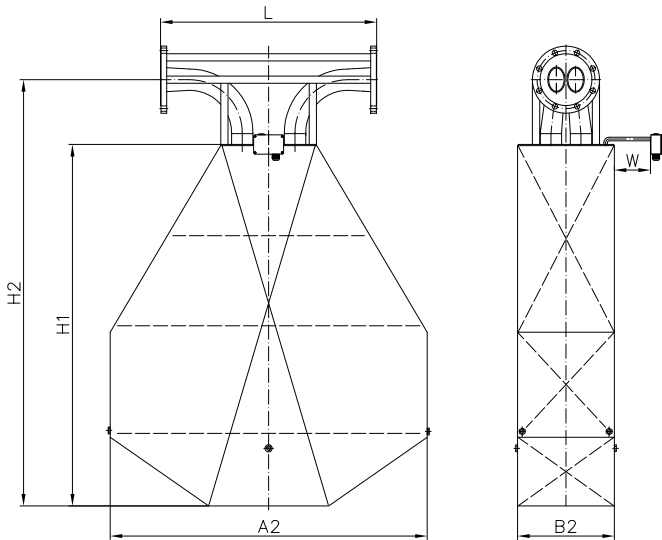

Process Connection	Face to face length (L)		Order Code
	mm	in	
ANSI 6" 150# RF	900	35.43	A1
ANSI 6" 300# RF	900	35.43	A2
ANSI 6" 600# RF*	900	35.43	A3
ANSI 6" 900# RF*	900	35.43	A7
ANSI 6" 1500# RF*	900	35.43	A9
ANSI 8" 300# RF	900	35.43	A6
ANSI 10" 300# RF	900	35.43	A8
ANSI 6" 900# RTJ*	900	35.43	R1
ANSI 6" 1500# RTJ*	900	35.43	R2
ANSI 6" 2500# RTJ*	900	35.43	R3
DIN DN150/PN16	900	35.43	D1
DIN DN150/PN40	900	35.43	D2
DIN DN150/PN100*	900	35.43	D3
DIN DN200/PN16	900	35.43	D8
JIS RF 10k 150A (6")	900	35.43	J1
JIS RF 20k 150A (6")	900	35.43	J2

For customization of face to face length and/or special fittings other than the ones listed on this page, please consult factory.
Note that larger diameter flange process connections are always possible.

A2 = 1320 mm (51.97 in) B2 = 403 mm (15.87 in) H1 = 1505 mm (59.25 in) H2 = 1775 mm (69.88 in) W = 150 mm (5.91 in)
 Electrical box: std. = 125 x 80 x 58 mm (4.92 x 3.15 x 2.28 in), RHE16 compact = 120 x 120 x 80 mm (4.72 x 4.72 x 3.15 in)

*This flange selection will reduce maximum allowable measurement tube pressure rating by a factor of 0.73.

Weights and Shipping Dimensions

Typical weight with 6" 150# flanges: approx. 380 kg (838 lb).

RHM80 meters ship in a wooden crate (to ISPM 15). Typical dimensions approx. 220 x 160 x 90 cm (87 x 63 x 36 in).

Typical gross shipping weight example: RHM80 with 4" 150# flanges c/w RHE08 transmitter approx. 550 kg (1213 lb).